

Measurement Tool for Exposure Techniques in X-ray Ionizing Radiation Equipment

Edwin Arley Cortes Puentes¹, Andres Gomez Rodriguez², Fernando Martinez Santa³
Universidad Distrital, Francisco Jose de Caldas
Bogotá, Colombia

Abstract—This article shows the development of an instrument for measuring the exposure parameters used to take radiographic studies in living beings; such as kilovoltage, current and time, since radiation protection is a fundamental pillar in the care of patients and operators of ionizing radiation equipment, it is necessary to calibrate these parameters in equipment that produce X-rays. For the manufacture of the measuring instrument is used an ESP32 microcontroller which is programmed using the Python syntax using the project micropython, in addition to current, distance and light sensors. The results of these measurements will be displayed through output devices such as organic light-emitting diode (OLED) displays, liquid crystal (LCD) displays, and a Web server, in order to perform the measurements safely from the control room and thus avoid exposure to radiation as much as possible. The kVp measurement performed in this article is for equipment operating at 60 [Hz], for high frequency equipment a new parameterization must be performed in order to obtain results as close to reality as possible. By using the web server for the transmission of measurement data, the radiation exposure was reduced and the calibration times of the equipment were improved. This article presents the measurements, and also the calculation of the error of each of the different exposure parameters of conventional X-ray equipments, such as kVp, mA, mAs and time. The errors obtained in the measurements were made assuming that the X-ray equipment used has a 0 error, i.e. assuming that the X-ray equipment is calibrated and that it is a standard equipment.

Keywords—Voltage; current; X-Ray; kVp; mA; mAs radiation; ESP32; OLED microcontroller

I. INTRODUCTION

The discovery of X-rays dates back to 1895 in the city of Hamburg, Germany and is due to experiments conducted by the physicist Wilhelm Conrad Röntgen, this contribution has been of great importance and usefulness in both industry and medicine. Radiation is emitted energy that is transferred through space with or without influence on the atomic structure of matter, it is classified into non-ionizing radiation and ionizing radiation according to the effects produced by corpuscular contact [1]. Non-ionizing radiation includes ultraviolet (UV), infrared (IR) and microwave radiation. In cells, the possibility that they can generate heat decay has been considered, but it is not yet known whether they can generate microscopic effects. Ionizing radiation includes X-rays, gamma, alpha and beta rays. These types of radiation are capable of creating damage or not in human cells [2]. In our body, ionizing action is evidenced by chromosome breaks, where changes may include consequent deletions or abnormal translocations, these effects can be seen during cell division resulting in abnormal cell development or death. The action of X-rays on sex cells can generate alterations in the transmission of hereditary characters

known as mutations. X-rays are electromagnetic radiation generated by the excitation of electrons in the internal orbit of an atom, with the ability to pass through opaque bodies. The wavelength range of X-rays is between 0.01 nm and 10 nm, which corresponds to an energy range of approximately 1 keV to 150 keV.

X-rays have been used extensively by humans in the fields of industry, veterinary medicine and medicine. In medicine they are used to obtain diagnostic images. As an example of its use we have panoramic and periapical equipment. Panoramic radiography is used to obtain a single image of the teeth and their supporting structures. Periapical radiography shows a more detailed image of the dental structure, it is used to explore the dental structure and the surrounding tissue. [3], mammograms: Mammography is one of the most important methods for detecting breast lesions. By means of this technique small anomalies can be identified which, if prevented in time, can be treated in a better way [4]. TACS “Computerized Axial Tomography” is a method that uses imaging technology for medical diagnosis, it allows to analyze the interior of the human body through millimetric transversal cuts to the cephalo-caudal axis, all this is done through the use of X-rays [5], C-arms, fixed and mobile X-ray equipment (they are used to obtain general X-rays of organs and bones), among others; These types of examinations, being non-invasive, represent a vital instrument for the analysis, study and care of animal and human health. Due to the imminent risk presented when using X-rays on living beings, it is essential to supervise and control the doses administered for such examinations.

However, in the process of diagnostic imaging, X-rays are used, which are dangerous, as it has been shown that they can generate negative eventualities to people. For this reason, and according to one of the pillars of radiation protection “as low as reasonably achievable” known as optimization, this indicates that the control elements of these devices must have the highest quality standards to obtain a good quality image with the lowest radiation dose [6].

Embedded systems work based on a processor, microprocessor, microcontroller or programmable logic devices, usually perform repetitive functions [7], therefore, we can find a variety of applications in practically all fields, from applications in bioengineering [8], as well as image processing [9], to industrial and educational levels as applications in industrial preventive maintenance [10] and control of didactic robots, respectively [11].

Since the beginning of mankind, human beings have sought their welfare in many ways, therefore any advance in technology has had approaches in medicine, embedded

systems have not been alien to this, have been developed applications as simple as drug dispensers [12] and others a little more complex, as is the control of vital signs [13] to the physiological emulation of the lung [14].

Speaking specifically of applications focused on everything related to X-rays, we can find various studies such as FPGA-based ionizing radiation detection [15], sample alignment devices for the diffractometer [16].

Thanks to all these advances in electronics in terms of sensors and embedded systems applied to the medical field [17], it is possible to perform increasingly faster and more precise measurements of X-ray exposure parameters (kVp, mAs, t) [18].

It is then intended to implement a system for measuring the exposure parameters kVp, mAs and time based on an ESP32 microcontroller, this in order to monitor and control the calibration of X-ray equipment and ensure the doses delivered to patients, thus this article is organized as follows: Section I gives an introduction on the parameters of exposure, the importance of X-rays and how embedded systems have been used in the area of medicine, Section II presents the design, which takes into account the electrical and mechanical characteristics that must be taken into account for the design of the same, Section III shows the data obtained from the measurements of the measurement system implemented, finally, Section IV presents some conclusions and recommendations that should be taken into account for future research.

II. DESIGN

This section explores the electrical, mechanical and electronic characteristics to be taken into account for the development of the measurement equipment, such as connectivity, power, voltage range, current range, time, materials, among others.

A. Measurement of Exposure Parameters

When a specific radiographic study is required, it is necessary to vary the parameters of peak kilovolts [kVp], current as a function of time [mAs] and time [t], because each patient has a different contexture, and each bone or organ of the body requires these parameters to be varied in order to obtain a good quality image that allows an accurate diagnosis.

1) *Exposure parameters influence on the acquired image:* Each exposure parameter varies the quality of the image to be acquired as follows:

kVp= Penetration "More or less opaque an organ" The higher the kVp applied, the higher the penetration of the X-rays and vice versa. mAs= Definition "Contrasts, grays" Allows to define the borders of the organs and to be able to distinguish between them [19]. t= Radiation exposure time. The longer an X-ray beam is the more penetration can be obtained in the image, however this parameter should be as low as possible without sacrificing the definition of the image, since the shorter the radiation exposure time of a patient the lower the risk of affecting the health of individuals.

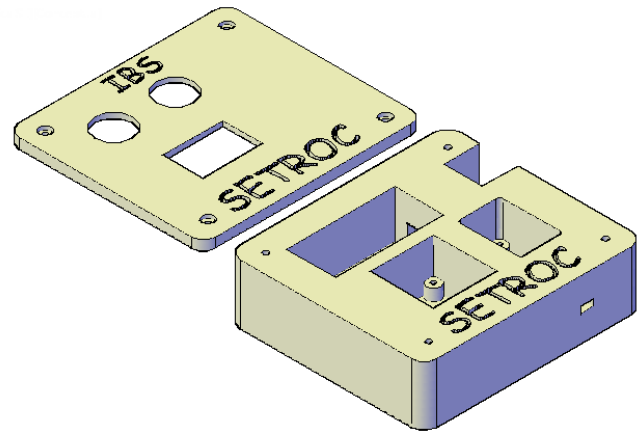

Fig. 1. kVp sensor box

B. Current Measurement

Conventional X-ray equipment generates a current in the range of $25[mA]$ to $500[mA]$, periapical and panoramic equipment uses lower values in the range of $3[mA]$ – $15[mA]$, the current in mammographs ranges from $20[mA]$ – $150[mA]$.

1) *Current sensor INA219:* The INA219 sensor allows current measurements from 0 to 400 [mA] and uses an I2C communication protocol compatible with the ESP32 microcontroller, which is why it is the current sensor module used by the measurement device proposed in this article.

C. High Voltage Measurement

Conventional X-ray equipment generates a voltage in the range of $30[kV]$ to $150[kV]$ with variations of $1[kV]$, mammographs operate between $20[kV]$ to $35[kV]$ because air at these voltages is ionized [20] To measure these voltage magnitudes, there is specialized equipment such as a blider or voltage dividers that allow an indirect measurement [21]. The phosphor screens used to take radiographs emit an intensity of light that is proportional to the kVp applied, this feature is used so that the measuring instrument designed in this article obtains the measurement of [kVp] indirectly.

1) *Light sensor for indirect kVp measurement:* The TSL-2591 sensor allows the measurement of the visible and infrared light spectrum separately, taking advantage of the light emanating from the phosphor screens and the sensor at the time of exposure, obtaining a digital constant that will be greater the higher the kVp applied and vice versa.

2) *Sensor box design:* Since the wavelength of light to be measured is in the visible light range, it is necessary to manufacture a box where the sensor and the phosphor screen are isolated from the light signals that may interfere with the measurement process. For this, the design is made in the AutoCAD software Fig. 1 and the .stl file is obtained, in this kVp sensor box is housed the light sensor, the phosphor screen that performs the measurement of kVp indirectly, plus a distance sensor installed in order to perform all measurements at the same distance and an OLED screen as user interface.

D. Time Measurement

Since the radiation from this equipment is ionizing, the exposure time is a parameter to be controlled, since the less time without sacrificing image quality the less radiation a patient will receive, it is necessary to measure the exposure time.

1) *ESP32 internal timer*: To perform the time measurement is used the *timer0* of the microcontroller *ESP32* that will use the signal emitted by the sensor *TSL2591* to start and end the trigger time count. This measurement is performed in the range of [ms], by tests performed the microcontroller can measure signals in the order of 15 [us].

E. Distance Measurement

Since the distance between the X-ray tube and the phosphor plate can be a factor in the measurement error, a distance sensor is used to ensure that the data acquisition is always at the same distance.

1) *HCSR04 sensor*: The *HCSR04* distance sensor is an ultrasonic type sensor that provides the possibility to measure distance in a range from 0 to 4 m with a sensitivity of 1 cm. It is installed next to the *Kvp* sensor in order to ensure that all measurements are made at the same distance and thus guarantee repeatability of the measurements made.

F. 20X4 OLED and LCD Display

After data acquisition, it is necessary to exchange information with the user, so that the user can acquire measurement information. Due to the practicality, size, low power consumption and connectivity with the *ESP32*, a 0.96" OLED screen will be used to display results on the *kVp* measurement device. In addition, the main control will use a 4x20 LCD coupled to an I2C module which facilitates the connection to the *ESP32* for the same purpose of being a user interface.

G. Web Server

Using the *Wifi* connectivity provided by the *ESP32* microcontroller, the measurement data obtained with the sensors is transmitted via a web server to a cell phone or laptop connected to the same network as the microcontroller. [22] This reduces the exposure to radiation and speeds up the verification and calibration process of the X-ray equipment, since the data transmission will be instantaneous via *wifi*.

H. ESP32

For the development of the measurement tool a development board is used that has integrated the *ESP32* family microcontroller that are manufactured by *espressif*, because this family of microcontrollers has *bluetooth* and *wifi* connection [23], By having *wifi* it is possible to create a web-server for the exchange of information *ESP32-Mobile* device, which is an advantage, since this allows to reduce the risk of exposure to X-rays by being able to exchange information from the control room of the X-ray equipment with the study room where the measurement equipment is located. Communications with the sensors and output peripherals are handled by *I2C* communication protocol [24]. Fig. 2 shows a

general diagram of the communications between the sensors, the microcontroller and the output peripherals. The flowchart shown in Fig. 3 shows the programming logic of the *ESP32*.

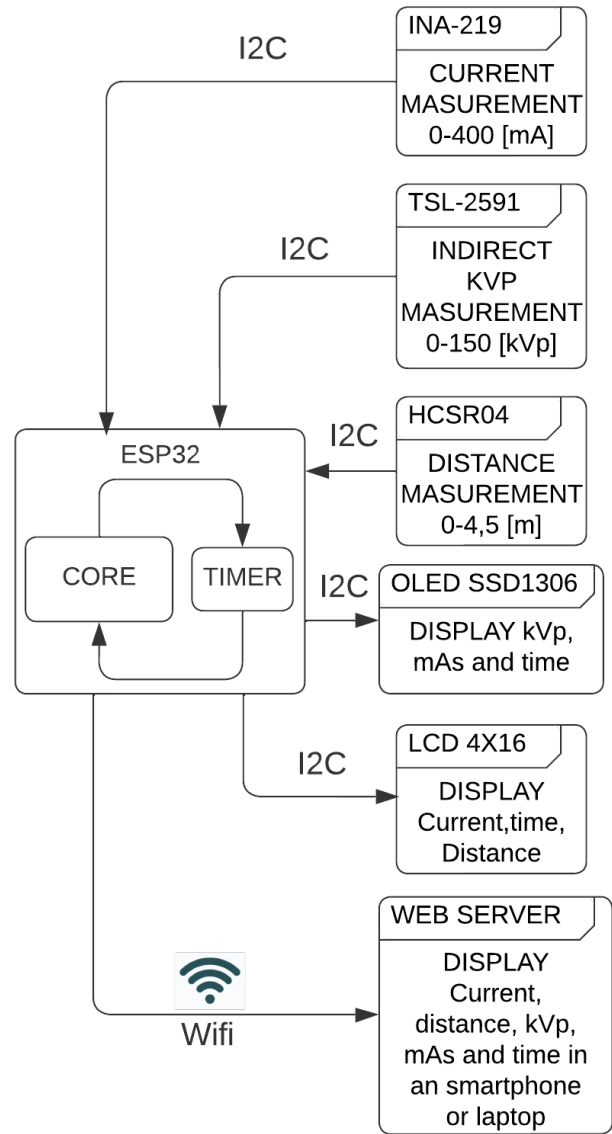

Fig. 2. General operating diagram

1) *Control box design*: In the control box is the current sensor (*INA219*), the *LCD 4x16* and the *ESP32* microcontroller, in turn is connected to the other sensors and peripherals output via *I2C* communications [25] with the sensor box *kVp*, *ESP32* processes the data obtained by the sensors and output signals are issued to the *OLED*, *LCD* and web server. For the design of the control box the *Autocad* software is used and the *.DWG* file is obtained, with which the cuts are made on a laser cutting machine, the cuts are shown in Fig. 4 The design of the box is shown in the Fig. 5.

III. RESULTS

This section shows the results obtained from the measurements made with the measurement equipment to an *Ameri-*

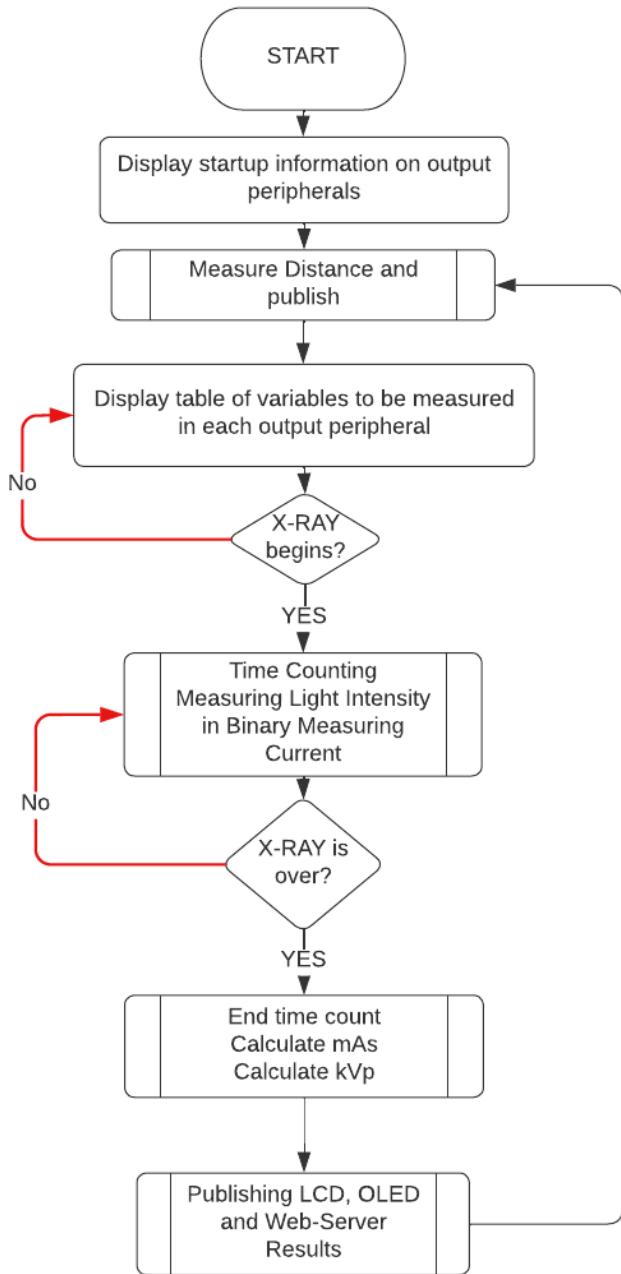

Fig. 3. General operating flow diagram

comp X-ray equipment model TXR-325, which operates in kVp from 30[kV]to150[Kv], in current from 0to500[mA] and in time from 0 to 5 [s], also are shown in this section the prototypes manufactured for the control box and sensor box kVp.

A. Case fabrication on 3D printer

Using a 3D printer, the kVp sensor box shown in the Fig. 6 is manufactured. First the design was made using the autoCAD software, the measures are 9x8x4 cm, once finished, it was exported to the 3D printer. The figure is recreated in a plastic, known as polylactic acid or PLA.

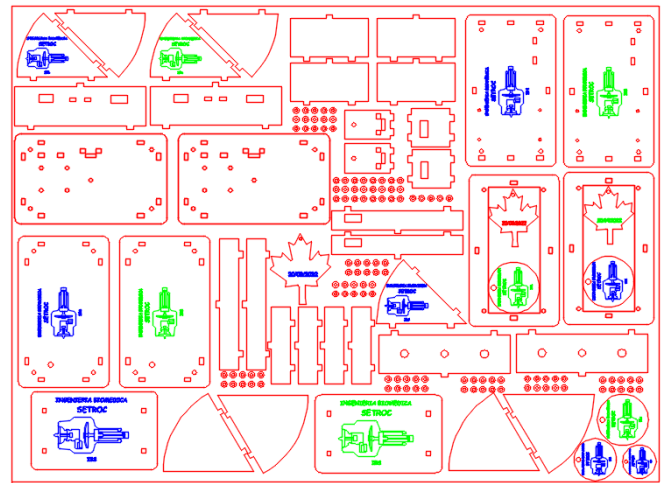

Fig. 4. Laser cuts

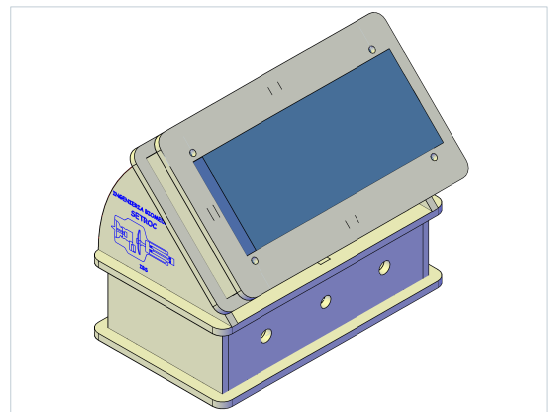

Fig. 5. Box Control

B. Laser Cutting Machine Control Box Manufacturing

Using a laser cutter, the kVp control box shown in the Fig. 7 was manufactured. First, the design was made using the autoCAD software, it was generated in 2D, the measurements are 7x12x3.5 cm, once finished, it was exported to the laser cutter. The figure is recreated in a 3 mm thick acrylic.

C. measurements Performed

The Fig. 8 shows the complete measurement prototype, with which the measurements presented in this article were performed, the results are displayed on the OLED, LCD and a Web server that displays the results; the Fig. 9 shows an example of how the data is viewed from the control room on the Web server from a device that can be a laptop or a Smartphone, thus the measurement is performed safely without exposure to radiation.

Since there is no standard equipment, the measurements presented in the article are made assuming an error of zero, i.e. assuming that the Americomp model 325 X-ray equipment on which the tests were performed is the standard equipment and it is assumed that it is calibrated.



Fig. 6. Prototype box sensor



Fig. 7. Control box prototype



Fig. 8. Measuring equipment prototype

kVp and mAs meter

Ingenieria Biomedica Setroc

Variable	medida	Unidades
V	110	[kVp]
I	200	[mA]
t	10	[ms]
I*s	20	[mAs]



www.ingenieriabiomedicasetroc.com

You can contact author at www.ingenieriabiomedicasetroc.com.
If you see any bugs, please [contact webmaster](#).
You may also want to visit us:
Setroc company, Bogota, Colombia

Fig. 9. Information published on web server

Similarly, the mean absolute error is calculated for each measured variable, using the formula in equation 1.

$$MAE = \frac{1}{n} * \sum_{i=1}^n |Y_i - X_i| \quad (1)$$

The analyzed measures are as follows:

1) Time measurement:

The time measurement is performed non-invasively by taking the TSL2591 sensor signal as the trigger start and termination signal for the ESP32 internal timer that keeps track

of the trigger duration time. The results of the measurements performed are shown in the Table I, where t_s is the set time and t_m is the time measured by the ESP32 internal timer.

The mean error for the calculated time is shown in equation 1, taking t_s as Y_i and t_m as X_i .

$$MAE = 2 \text{ ms}$$

2) *Current Measurement:* The current measurement is performed invasively by placing the INA219 sensor in series with

TABLE I. TIME MEASUREMENTS

t_s	t_m	Error
100[ms]	101[ms]	1%
200[ms]	199[ms]	0.5%
300[ms]	299[ms]	0.33%
400[ms]	402[ms]	0.5%
500[ms]	501[ms]	0.2%
800[ms]	803[ms]	0.37%
1000[ms]	1005[ms]	0.5%

the secondary of the high voltage transformer and communicating the measurement to the ESP32 via I2C communication. The results of the measurements are shown in the Table II, where I_s is the set current and I_m is the measured current.

TABLE II. CURRENT MEASUREMENTS

I_s	I_m	Error
50[mA]	51[mA]	2%
55[mA]	53[mA]	3,64%
60[mA]	57[mA]	5%
70[mA]	69[mA]	1,43%
80[mA]	78[mA]	2,5%
90[mA]	91[mA]	1,1%
100[mA]	99[mA]	1%
150[mA]	147[mA]	2%

The calculated mean current error is shown in equation 1, taking I_s as Y_i and I_m as X_i .

$$MAE = 1,75 \text{ mA}$$

3) *mAs Measurement*: Having the current and time measurements we can find the measured *mAs* using the equation 2, where I_m and t_m are the results of the current and time measurements respectively, the results obtained from the calculated *mAs* measurements are shown in the Table III where mAs_s is the $mAs_{selected}$ and mAs_m is the $mAs_{measured}$.

$$mAs = I_m * t_m \quad (2)$$

TABLE III. MAS MEASUREMENTS

mAs_s	mAs_m	Error
50[mAs]	51[mAs]	2%
100[mAs]	104[mAs]	4%
200[mAs]	203[mAs]	1,5%
300[mAs]	302[mAs]	0,67%
400[mAs]	397[mAs]	0,75%
500[mAs]	496[mAs]	0,8%

The mean error for the calculated mAs is shown in equation 1, taking mAs_s as Y_i and mAs_m as X_i .

$$MAE = 2.83 \text{ mAs}$$

Fig. 10 shows a diagram of the general operation of the kVp meter. The kVp measurement is done indirectly, to find the kVp value the microcontroller makes use of the digital value in binary number delivered by the visible light sensor and making use of the equation 3 calculates the measured kVp value. In the equation 3, N_{binary} is the binary number read by the sensor at the time of exposure and K is the constant found through testing. The results of the kVp measurements performed are shown in the Table IV where kVp_s is the kVp

set in the X-ray equipment, kVp_m is the kVp measured with the measuring equipment.

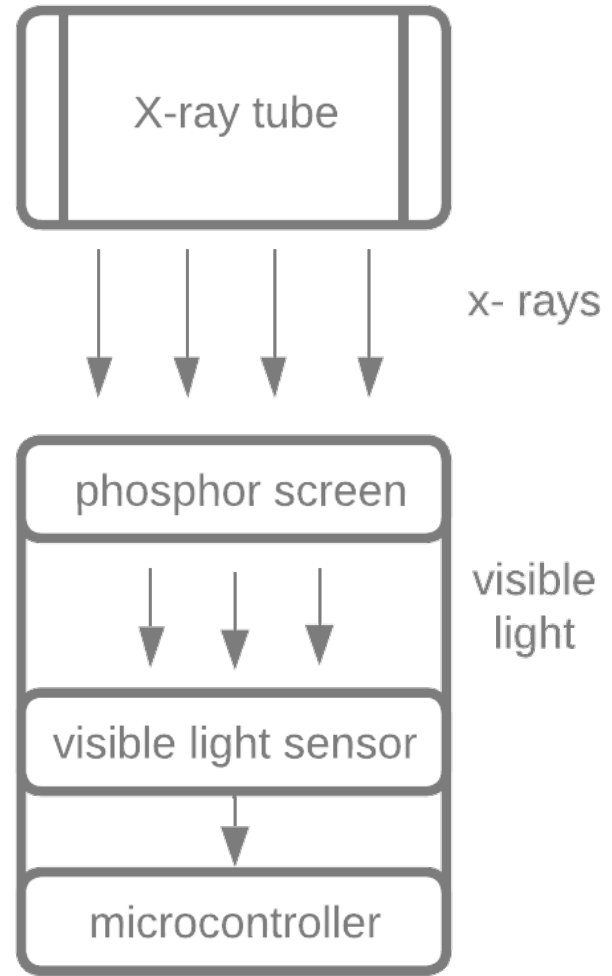

Fig. 10. General operation of kVp meter

$$kVp = N_{binary} * K \quad (3)$$

TABLE IV. kVp MEASUREMENTS

kVp_s	kVp_m	Error
50[kVp]	51[kVp]	2%
55[kVp]	53[kVp]	3,64%
60[kVp]	57[kVp]	5%
70[kVp]	69[kVp]	1,43%
80[kVp]	78[kVp]	2,5%
90[kVp]	91[kVp]	1,1%
100[kVp]	99[kVp]	1%
150[kVp]	147[kVp]	2%

The mean error for the calculated kVp is shown in equation 1, taking KVps as Y_i and KVpm as X_i .

$$MAE = 1,75 \text{ kVp}$$

4) *Distance measurement*: The distance measurement made by the ultrasonic sensor between the collimator and the

fabricated sensor is compared with the measurements taken with a flexometer, the results of the measurements made are shown in the Table V, it should be noted that the kVp measurements were made at a distance of 1[m].

TABLE V. DISTANCE MEASUREMENTS

Distance	Distancie _m	Error
10[cm]	9, 8[cm]	2%
20[cm]	19, 9[cm]	0, 5%
35[cm]	35, 1[cm]	0, 28%
50[cm]	49, 7[cm]	0, 60%
80[cm]	80, 2[cm]	0, 25%
90[cm]	89, 9[cm]	0, 11%
100[cm]	99, 8[cm]	0, 2%

The mean error for the calculated distance is shown in 1, taking distance as Yi and measured distance as Xi.

$$\text{MAE} = 0,17 \text{ cm}$$

The measurement instrument designed allows to have an impact in favor of the health of the operators and users of the machines in charge of generating the X-rays, due to the fact that the exposure to radiation decreases when carrying out the measurements in short times and also through of the webserver tool and an IP to transmit and view them in a control booth.

IV. LITERATURE REVIEW

The articles used as reference in this research are in common agreement on how important it is to minimize the time and distance of exposure to X-rays, finally, we can find concepts, methodologies and proposed applications focused on different areas such as biomedicine for means of embedded systems.

That is why applications have been proposed that seek to be less exposed to these rays, such as the one created through Atmega328p, with the limitation that it is only for Android devices, since it is implemented under an application or the one designed by means of the intel386EX for the real-time communication system of a moving vehicle but only for a closed network.

V. CONCLUSIONS

The impact of the media system designed in the field of medicine is very important and improves because it allows monitoring the X-ray equipment from a mobile device keeping a prudent distance from it, which generates a positive benefit for patients and operators, the first they could have a more optimal and efficient team, and the latter would avoid the recurring exposure to which they are immersed

It is common knowledge that exposure to X-rays generates short, medium and long term damage to health, therefore it is of vital importance to seek solutions that allow users and operators to mitigate these health consequences, that is why from our branch, we thought and implemented a measurement system that can be operated and monitored remotely.

The specification of the controller is vital for the desired application, in this case an ESP32 was selected, as it has the advantage of connecting to WIFI natively, which makes it ideal for Internet of Things (IoT) type projects such as the one developed, likewise its low cost is another added value.

This measuring equipment allows measurements in conventional equipment operating at 60 [Hz], since in high frequency equipment additional factors must be considered. By the fact that the tests showed the importance of having sensors with a high response speed, because to sample a signal with a frequency of 60[Hz], you must have a sensor module that performs the measurement and makes the transmission of information at least 2[ms], in order to reconstruct a signal.

For this type of measurements it is important to have sensors with a high response speed, since it is necessary to sample signals in the order of [ms], in the implementation of the proposed measurement system was one of the problems presented, because it was not possible to generate the expected signal, simply obtaining measurement points that did not indicate anything, the solution was a sensor with higher speed performance, thus the rectified signal was acquired.

As a future improvement for the proposed media system, it is recommended to use a sensor that is faster in terms of data processing, as this could make the data acquisition for the kVp variable more accurate.

For future research where it is required to implement a control or measurement prototype, it is recommended to have the appropriate protective equipment for work with X-rays.

It is important to keep the traceability of the error of the designed measurement system, for this, it is proposed as an improvement for the future, to use a standard equipment, since with a calibrated instrument we can know the real error of the equipment, and then compare it with our system.

ACKNOWLEDGMENT

I thank the ARMOS research group of the Universidad Distrital Francisco José de Caldas, especially the engineer Fernando Martinez Santa who as a teacher directed the project and also the company Ingenieria Biomedica Setroc for allowing us to run experimental tests under the direction of Daniel Cortes who provided his knowledge and experience in the area for the realization of this project.

REFERENCES

- [1] M. V. D. Villca, "Historia de la radiología," *Revista de actualización clínica Investiga*, vol. 37, p. 1787, 2013.
- [2] A. Buzzi, "El descubrimiento de los rayos x," *Buenos Aires, Argentina*, 2012.
- [3] C. T. Venegas, "Historia de la medicina: un cincuentenario.-el descubrimiento de los rayos x," *Revista de la Facultad de Medicina*, vol. 14, no. 1, pp. 60-63, 1945.
- [4] F. Marquez, N. Acosta, T. Benavente, and M. Poma, "Dosis en mamografía: Estudio preliminar," *Revista de Investigación de Física*, vol. 5, no. 01-02, 2002.
- [5] C. Pereira, "Tomografía axial computada," *XIII Seminario de Ingeniería biomédica*, 2004.
- [6] W. S. Castrillón-Giraldo, J. M. Aramburo, and W. Jaramillo-Garzón, "Control de calidad en equipos de rayos x en intervencionismo," *Revista Colombiana de Cardiología*, vol. 27, pp. 88-95, 2020.
- [7] D. Pérez, "Sistemas embebidos y sistemas operativos embebidos," *Lecturas en ciencias de la computación. Universidad Central de Venezuela, Vols.% i de% 2ISSN*, pp. 1316-6239, 2009.
- [8] P. A. García, "Sistemas embebidos de tiempo real con aplicaciones en bioingeniería," Ph.D. dissertation, Universidad Nacional de La Plata, 2019.

- [9] L. Sugezky, M. Prieto, N. González, M. Giura, Y. Kuo, M. Trujillo, and J. Cruz, "Desarrollo e implementación de herramientas de simulación de modelos para sistemas embebidos," in *Congreso Argentino de Sistemas Embebidos*, 2016.
- [10] W. Hasperué, C. A. Estrebou, G. Camele, P. López, M. Peña, R. Zambrano, L. C. Lanzarini, A. Fernández Bariviera, and M. Cerrada, "Procesamiento inteligente de la información: aplicaciones en bioinformática, trayectorias vehiculares, mantenimiento preventivo industrial y sistemas embebidos," in *XXIV Workshop de Investigadores en Ciencias de la Computación (WICC 2022, Mendoza)*, 2022.
- [11] D. Azcurra, S. Rojo, and D. Rodríguez, "Arquitecturas de control para robots autónomos móviles didácticos basadas en sistemas embebidos," in *XIV Workshop de Investigadores en Ciencias de la Computación*, 2012.
- [12] P. M. B. Bastidas, J. D. C. Vallejo, C. A. L. Narváez, D. M. Torres, and R. G. M. Perafán, "Dispensador automático de medicamentos sólidos para pacientes mediante uso de sistemas embebidos," *Boletín Informativo CEI*, vol. 7, no. 3, pp. 88–94, 2020.
- [13] W. R. Ruiz Sánchez *et al.*, "Redes de sensores inalámbricos enfocadas a la medicina con énfasis en control de los signos vitales en pacientes adultos mayores," Master's thesis, PUCE, 2016.
- [14] J. S. Agudelo Díaz and O. A. Cardoza Olano, "Emulación de la fisiología respiratoria del pulmón empleando un sistema embebido." 2022.
- [15] C. R. A. N. LAVEAGA, D. A. A. F. JARAMILLO, and D. C. D. GALVÁN, "Desarrollo de un sistema embebido para detección de radiación ionizante para seguridad civil," 2016.
- [16] D. S. Jiménez-Novoa, J. S. González-Bustamante, and W. Aperador-Chaparro, "Dispositivo de alineación de muestras para el difractor de rayos x con control de posición e interfaz de manipulación," *Respuestas*, vol. 22, no. 1, pp. 84–95, 2017.
- [17] S. Widadi, M. K. Huda, I. Ahmad *et al.*, "Atmega328p-based x-ray machine exposure time measurement device with an android interface," *Journal of Robotics and Control (JRC)*, vol. 1, no. 3, pp. 81–85, 2020.
- [18] J. Gázquez, F. Guillen, N. Novas, and M. Berenguel, "Diseño e implementación de un sistema de comunicación en tiempo real y tolerante a fallos para monitorización médica en vehículo en movimiento," *XXV Jornadas de Automática*, 2004.
- [19] O. Lakhwani, V. Dalal, M. Jindal, and A. Nagala, "Radiation protection and standardization," *Journal of clinical orthopaedics and trauma*, vol. 10, no. 4, pp. 738–743, 2019.
- [20] D. B. Silva, M. A. Santos, F. R. Barros, L. A. Santos *et al.*, "High precision instrumentation for measuring the true exposure time in diagnostic x-ray examinations," 2013.
- [21] F. J. R. Campos, "Prácticas de alta tensión para fines didácticos en ingeniería," *Ingeniería e Investigación*, no. 13, pp. 45–54, 1986.
- [22] L. García, J. M. Jimenez, J. Lloret, and P. Lorenz, "Wifi and lora energy consumption comparison in iot esp 32/sx1278 devices," in *SMART 2019, The Eighth International Conference on Smart Cities, Systems, Devices and Technologies*. IARIA XPS Press, 2019, pp. 26–31.
- [23] I. Allafi and T. Iqbal, "Design and implementation of a low cost web server using esp32 for real-time photovoltaic system monitoring," in *2017 IEEE electrical power and energy conference (EPEC)*. IEEE, 2017, pp. 1–5.
- [24] E. J. Carletti, "Comunicación-bus i2c," *Robots Argentina*, 2007.
- [25] P. Bertoletti, *Proyectos con ESP32 y LoRa*. Editora NCB, 2019.