

Supervisory Control and Data Acquisition System for Machines Used for Thermal Processing of Materials

Diego Patiño¹, Wilson Tafur Preciado², Albert Miyer Suarez Castrillon³, Sir-Alexci Suarez Castrillon⁴

Electronic Engineering, University Francisco of Paula Santander, Cúcuta, Colombia¹

Faculty of Engineering and Architecture, University of Pamplona, Pamplona, Colombia^{2, 3}

Faculty of Engineering, University Francisco of Paula Santander Ocaña, Ocaña, Colombia⁴

Abstract—A supervisory control and data acquisition (SCADA) system has been developed for three machines used for the thermal processing of materials: a hot wire cutter, an induction heater and a welding test stand. The cutter uses a transformer with adjustable voltage between 20 V and 32 V, and current of 8 A, measuring the temperature of the wire with thermal expansion. The heater uses a 24 V, 15 A sources, and a type K thermocouple embedded in the sample in order to measure temperature. In welding, a temperature control system was implemented for the sample using type K thermocouple and a cooling fan using a 12 V and 20 A sources. The SCADA system consists of a PLC and a PC with a graphical interface which serves to select the process to be worked on as it displays the thermal history of the monitored object. The supervisory system uses a PC with a 32-bit Windows 7 operating system and an OPC software package running on the academic LabVIEW platform. It was designed to use a single human-machine interface for different thermal processes. This paper describes the important components of the system, including its architecture, software development and performance testing.

Keywords—Automatic control of thermal processes; programmable logic controllers; monitoring and supervision in automatic control systems; machine components; Sensors and virtual instruments for control

I. INTRODUCTION

The thermal processing of materials requires keeping track of the measurement of temperatures and their behavior over time, in order to record the thermal history and understand the physical phenomena inherent to each process.

The hot wire cutting machine uses a chrome-nickel alloyed wire between 0.5 and 1 mm in diameter, heated under the Joule effect [1] produced by a source of electrical energy that allows the current to circulate through the wire. When adjusting the operating parameters of the machine, it is always necessary to specify the temperature of the wire and the speed with which the cut must be executed [2]. In addition, the wire must be kept tensed in order to cut certain materials such as foams and Styrofoam [3].

In the case of welding processes, the thermal information of the sample is useful, as it is welded to describe the process phenomena from the point of view of its technology, metallurgy and heat transfer, as required in the development of welding procedures [4]. The measurement of temperatures below the weld bead and its location with respect to the bead is

useful to use a computer program [5], [6], which predicts the temperature distribution of the welded sample. In the particular case of welding materials sensitive to high temperatures, such as manganese-alloyed steels, it is necessary to keep the temperature of the sample below 250°C so as to keep the material from cracking. Fans can be used to cool the sample before continuing to make new welding deposits [7].

The induction heating machine is used for treating ferrous materials with heat [8]. In this case study, small cylindrical samples were heated in order to obtain their heating, maintenance, and cooling cycles. The thermal history experienced by the treated material is of vital importance to learning the behavior and mechanical properties that it will present when used.

In order to be able to interact with the thermal processing machines located in the same laboratory space, a Supervisory Control and Data Acquisition (SCADA) system that supervises and controls the variables present is required. This is achieved with the use of a graphical interface platform such as Labview from National Instruments, and the STEP 7 Micro WIN application for programming the Programmable Logic Controller (PLC) [9]. Other applications have been used for data acquisition in the laboratory and for the control of variables [10]–[13], as is intended with thermal processing machines. No sophisticated temperature control systems were developed [14]–[16], but results were achieved without signal interference.

In this paper, three machines were connected to the SCADA system and, consequently, threads were developed in the PLC to use a single graphical interface from a personal computer (PC). A “Human Machine Interface” (HMI) was designed with control panels for each machine, which can be selected by the user to operate the machines independently.

To describe the SCADA system proposed, the hardware implementations are presented, while the interface developed and the logic applied for the three machines are explained. The three machines used operate independently. These are: the hot wire cutting machine, the induction heating machine and the welding test machine. The rest of the sections in this paper are organized as follows: The next section illustrates the Hardware and Logical interface of the supervisory system. The results are comprehensively presented and discussed in section Results and Discussion.

II. METHODOLOGY

To describe the SCADA system proposed, the hardware implementations are presented, while the interface developed and the logic applied for the three machines are explained. The three machines used operate independently. These are: the hot wire cutting machine, the induction heating machine and the welding test machine.

A. Hardware for the Supervisory System

The system architecture is made up of an HMI interface in charge of supervising the thermal variables of the materials treated and inserting the initial parameters for its execution and a PLC connected to each machine. The PLC is an S7-200 from Amsamotion that has 14 digital inputs and ten digital outputs.

In the cutting machine, PLC controls the movement of the motor and regulates the voltage of the wire, taking the readings of the current and expansion of the wire (Fig. 1). This information is sent to the HMI interface so that the operator can see the thermal behavior of the machine.

The PLC can only apply ON/OFF logic to control the coil in the induction heating machine since it works with a fixed voltage of 24 V (Fig. 2). This machine's interface only shows the temperature of the sample throughout its thermal cycle, that is, the temperature and the time it takes to reach its maximum point and the time it takes to reach ambient temperature.

In the welding machine, the preheating temperature and the temperature at the welding point are monitored (Fig. 3). The functions of the interface for this machine is to set the desired preheat temperature and display the data from the two temperature sensors. This is achieved through two thermocouples connected from the PLC. Additionally, a fan used to cool the sample is directly connected.

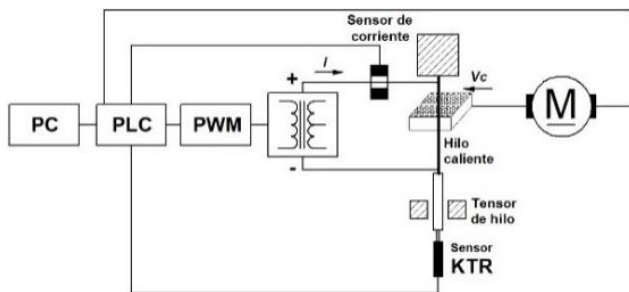

Fig. 1. Structure of the SCADA System on the Hot Wire Cutting Machine.

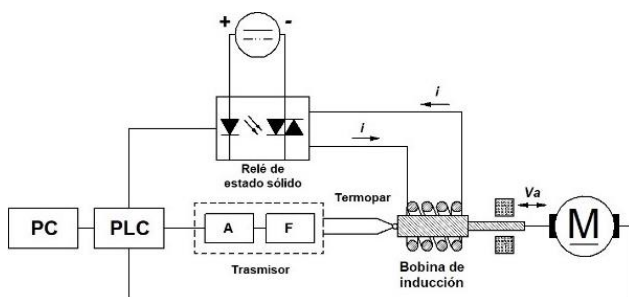

Fig. 2. Structure of the SCADA System in the Induction Heating Machine.

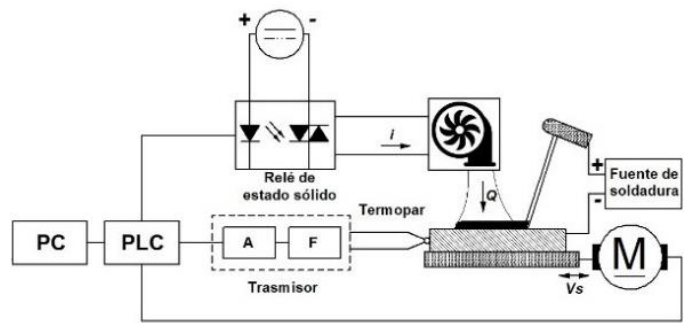

Fig. 3. Structure of the SCADA System in the Welding Machine.

Because the machines are linked to the same PLC, a bar with eight switches was implemented to connect the five sensors (Fig. 4).

It is thus possible to use all five sensors with only two analog inputs. However, only one machine's sensors can be used at a time.

For the operation of the Brushless motor, it was necessary to add a controller that allows manipulating the direction of the motor's rotation and varying the speed. Likewise, to determine the motor's position, Hall Effect sensors were connected to the input pins of the PLC to determine the exact position of the motor's rotor.

For the hot wire cutting machine, a linear expansion sensor and a current sensor are connected to the PLC, manipulated by means of pulse width modulation (PWM). Likewise, the Q0.2 output is connected to an electrical circuit that allows the average voltage flowing through the wire to vary.

Induction heating is commanded by pin Q0.4, which turns the coil on and off. In addition, a type K thermocouple connected to pins 5 and 6 of the switch bar is used, which is in turn connected to the analog input +A of the PLC [17].

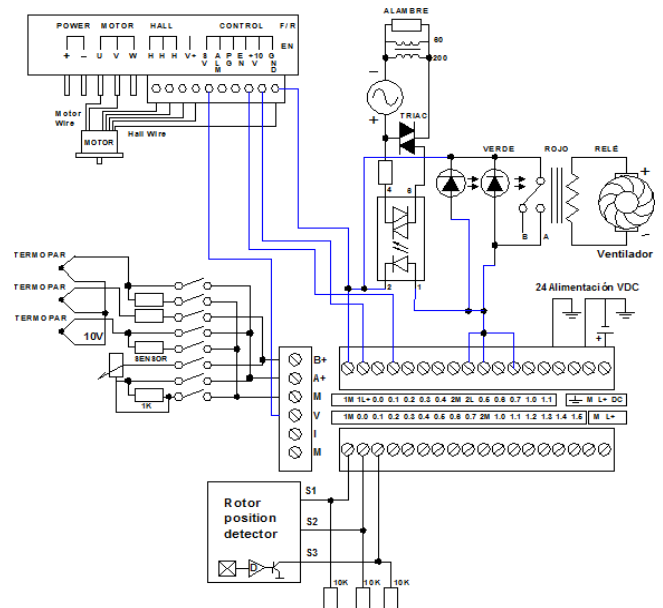

Fig. 4. Structure of the SCADA System in the Induction Heating Machine.

Finally, the pins used for controlling and monitoring the welding machine are Q0.6 and Q0.7, indicating the welding application or the halt of the process. Likewise, pin Q0.8 is responsible for activating or deactivating the fan.

B. Logical Interface of the Supervisory System

For the development of the HMI interface, the LabVIEW computational tool is used. Four virtual instruments (VIs) were implemented: one main instrument (Fig. 5) and three additional ones.

The interface of the hot wire cutting machine (Fig. 6) specifies the configuration of the wire according to its type and dimensions, the maximum current values, temperature, and expansion, in addition to the length of the wire and its electrical resistance. Next, the operating parameters are regulated, namely the voltage of the source and the cutting speed.

A graph is displayed for the current flowing through the wire and another for the temperature measured through the thermal expansion of the wire.

In the interface of the induction heating machine (Fig. 7), the preheat temperature of the workpiece is set. Initially, the sample is heated until it stabilizes at an initial temperature. A ramp then raises the temperature from the initial to the final temperature. In addition, the conditions of the sample are specified, namely initial temperature, length and speed of advance to indicate movement in one direction, in the opposite direction or in alternating direction.



Fig. 5. Main Interface.

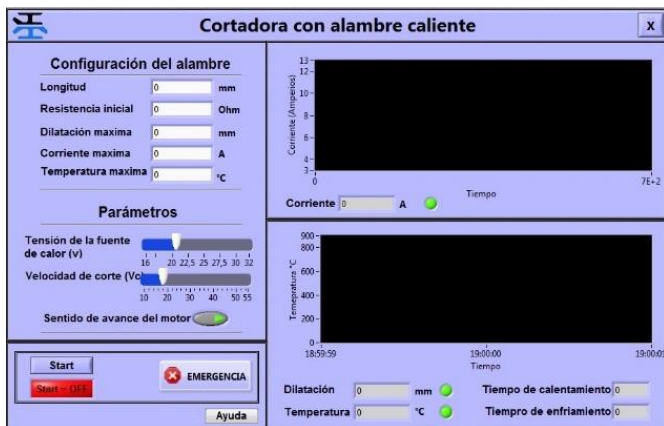

Fig. 6. Hot Wire Cutting Machine Interface.



Fig. 7. Induction Heating Machine Interface.

The temperature that the sample finally reaches is graphically represented to observe the thermal history of the material.

For the interface of the welding testing machine (Fig. 8), the expected preheating and maximum temperatures must be entered, as well as the welding speed for the movement of the sample with respect to the electrode both in forward or reverse directions.

The two thermocouples installed in the sample measure the temperatures below the welding bead and their temperature. These are displayed graphically on the screen and the data is processed for analysis of thermal cycles in welding.

Regarding the software, in addition to the VIs for the interfaces, an automation was designed in the control algorithm for the PLC with the functionalities of the three machines. The PLC programming language used was Ladder, along with the LabVIEW "Object Linking and Embedding for Process Control" (OPC) module for communication between PC, PLC and sensors.



Fig. 8. Weld Testing Machine Interface.

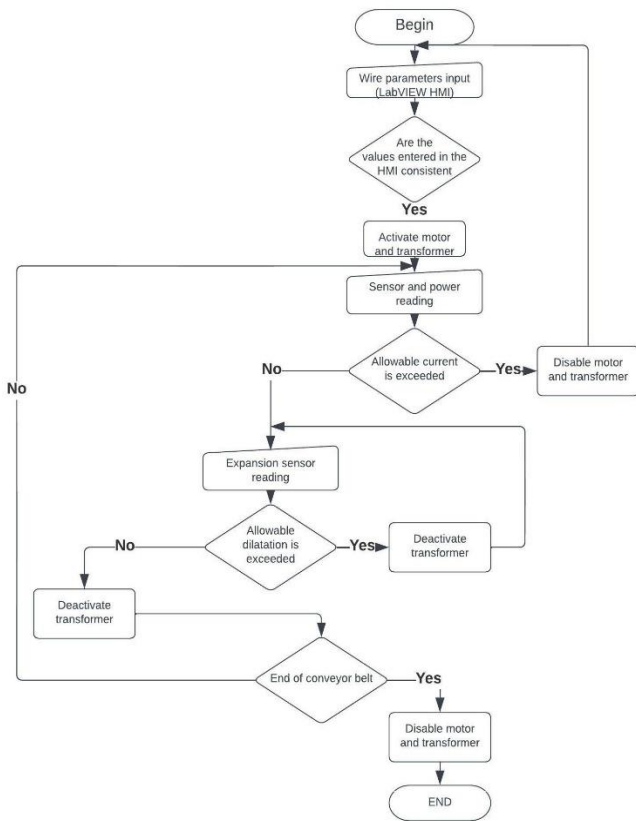

Fig. 9. Flow Chart for Hot Wire Cutting Machine.

The logic of the hot wire cutting machine (Fig. 9) consists of checking the coherence of the entered values, checking the allowed current and the expansion, and finally deactivates the motor and the transformer.

The operating logic for the induction thermal processing machine (Fig. 10) verifies the preheating of the sample and on the other hand the parameters, so as to visualize the temperature ramp with respect to time.

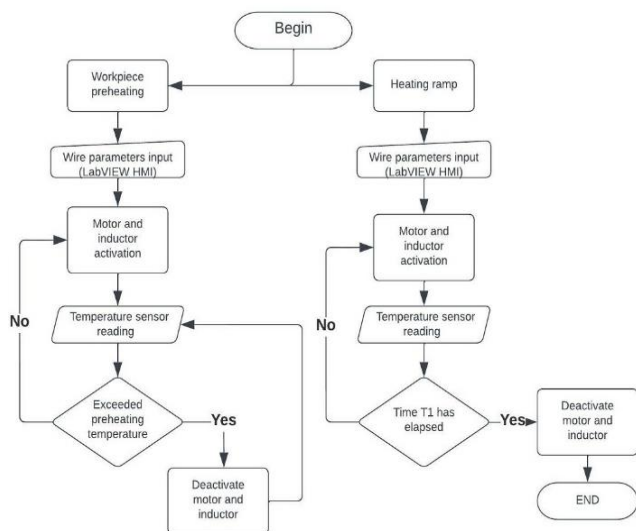

Fig. 10. Flow Chart of Induction Heating Machine.

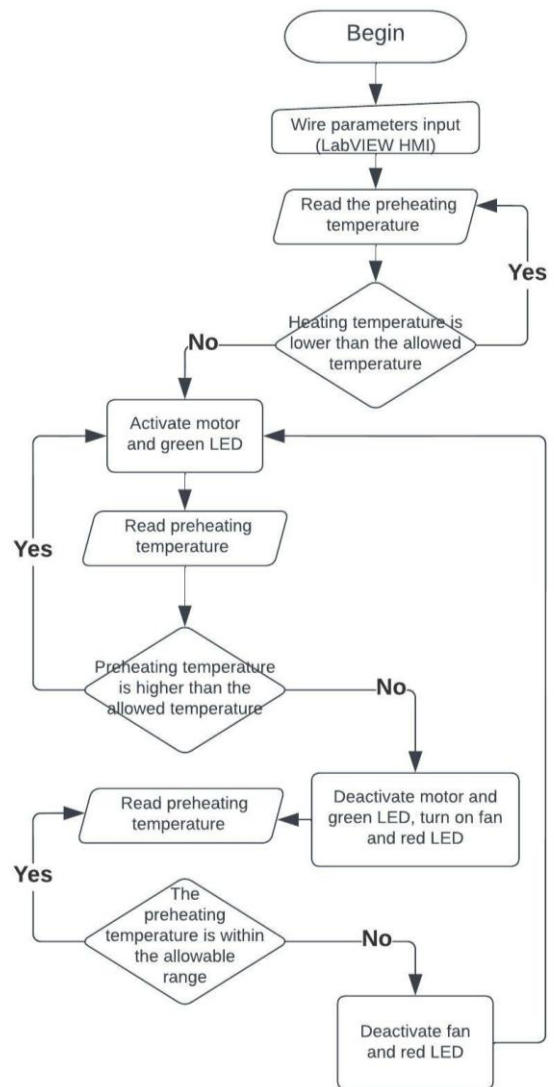

Fig. 11. Flow Chart of the Welding Testing Machine.

The logical process required to work the welding machine (Fig. 11) begins by specifying the preheating temperature of the sample to be welded, delimiting the allowed range. If the temperature is below the range, a red light will go on, indicating that welding cannot start. If the temperature is above the allowed range, it means that the welding must stop and a fan must be activated to cool the welded sample.

III. RESULT AND DISCUSSION

Based on the mechanical design of the machines and the manufacture and installation of components previously carried out by the company Ingeniería Brasilerio Colombiana SAS, the automation of the thermal processes was carried out using the SCADA system. First, a transformer with variable voltage between 18 V to 30 V of alternating current (AC) was designed and installed, controlled from the PLC by means of an Optotriac used as an interface between the controller and the power Triac of the transformer, in order to vary the voltages. The maximum amperage reached was 9A. Fig. 12 shows the implementation of the hot wire cutting machine.



Fig. 12. Implementation of the Hot Wire Cutting Machine.

Then, a KTR-type displacement sensor was implemented. Since it is welded to the counterweight that tenses the wire, it manages to measure the linear expansion caused by its heating. This sensor measures from 0 cm to 2.5 cm, and has a maximum error of 0.02 mm. Measuring the linear thermal expansion of the wire when heated allowed making an indirect measurement of temperature using (1).

$$T_f = T_o + (L_f - L_o) / \alpha L_o \quad (1)$$

Where, L_f and L_o are the final and initial lengths of the wire; T_f and T_o are the final and initial temperatures of the wire; and α is the coefficient of thermal expansion obtained from the wire manufacturer.

In addition to those with variable voltage, tests were carried out using a transformer with a fixed voltage of 20 V. This was done to determine the reliability of the SCADA system function and to compare its accuracy. In this way, it was possible to determine the feasibility of using PWM to manipulate the output and obtain different voltages to heat the wire. Table I shows the comparison between the two voltage sources. A wire with a diameter of 0.7 mm was used for this, varying between three different lengths (800 mm, 900 mm and 1000 mm), as shown. To obtain an acceptable margin of error, three iterations were performed for each length value, with a total of 9 samples for each source.

TABLE I. HOT WIRE TESTS

Length (mm)	Variable source		Fixed source	
	T_{\max} (°C)	I (A)	T_{\max} (°C)	I (A)
800	788	8.7	779	8.6
800	791	8.7	780	8.6
800	790	8.7	784	8.6
900	651	8.2	642	8.15
900	654	8.2	640	8.15
900	649	8.2	640	8.15
1000	583	8	576	8
1000	585	8	578	8
1000	580	8	576	8

When comparing the temperatures measured with each source, a maximum error of 5 °C can be seen. With this error in mind, the use of the sensor can be considered as a good alternative to measure the temperature indirectly in the wire. It is also possible to validate that the results obtained with variable tension are consistent with those obtained with fixed tension.

In the tests with the induction heating machine, an Adeeing Flyback heating plate of 1000 W and 20 A was used for low voltage induction ZVS between 12 V and 48 V. The power supply is carried out with a 24V DC switched source with 15A DC current. The steel sample to be heated must dimensionally comply with a 1/3 ratio between diameter and length [18] for effective induction in thermal processing. Thus, the sample was 15 mm in diameter and 45 mm in length. Simulation tools can also be used to determine the parameters of the induction coil [19]. Fig. 13 shows how the test body reached the bright cherry red required to treat steel with heat. The temperature in these conditions must exceed 700°C up to a maximum of 1100°C. The measurement made with the thermocouple verified that the temperature reached in the process exceeded 700°C. The design of the coil was beneficial for this positive result: it was made of 6 mm diameter copper tubing, obtaining a 7-turn cylindrical shape with an internal diameter of 35 mm and a height of 50 mm. In another phase, the programming of a heating ramp from an initial temperature to a final temperature was tested. This was done by configuring the ignition time of the coil with an ON/OFF control commanded from LabVIEW.

In order to determine the best location of the thermocouple tip with respect to the center of the coil, four tests were performed at distances of 0, 5, 10 and 15 mm.

The thermocouple placed in the middle of the inductor presents a high interference (green line in Fig. 14) due to the magnetic field generated by the coil. When the thermocouple is withdrawn 15 mm, the interference disappears (blue line in Fig. 14). This was confirmed by previous experiments [20].

Finally, the implementation in the welding testing machine was carried out. In it, a car powered by a Brushless motor, previously used in the cutting machine, a press was adapted to hold the sample to be welded. Two K-type thermocouples were inserted into a steel plate to monitor temperatures. For each thermocouple, a transmitter that amplifies and filters the temperature signal to take it to the PLC was used. From the HMI interface, the motor was activated to move along the car with the sample at the welding speed when the electric arc was ignited (Fig. 15).



Fig. 13. Induction Heating Test.

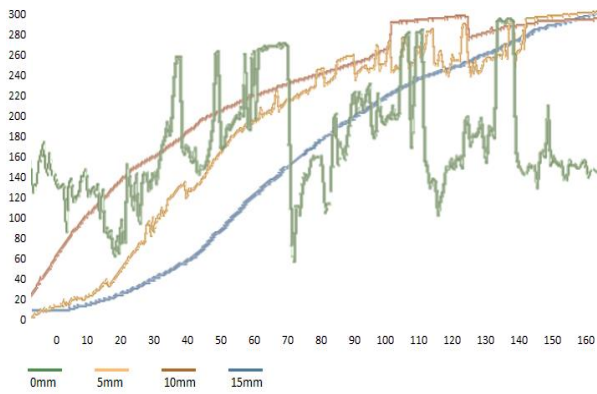

Fig. 14. Preheat Temperature at Different Distances from the Coil Center.



Fig. 15. Implementation in the Welding Testing Machine.

Two lights (one red and one green) are placed on the machine to indicate when the temperature to start welding is reached, which turns on the green light. The red pilot lights up when the sample reaches the maximum temperature previously specified on the HMI. When this happens, a fan that accelerates the cooling of the sample is activated to continue the welding operations.

Additionally, a 12 V and 20 A switching power supply was used to start the fan. The location of the thermocouple tip with respect to the heat source (the electric arc) is also important in order to avoid interference in the signal due to the magnetic field of the welding current, as happens when the thermocouple is moved between 5 and 10 mm away (Fig. 16). A way to measure the temperature in welded plates is thus indicated in comparison with modern techniques [21] and analytical methods [22].

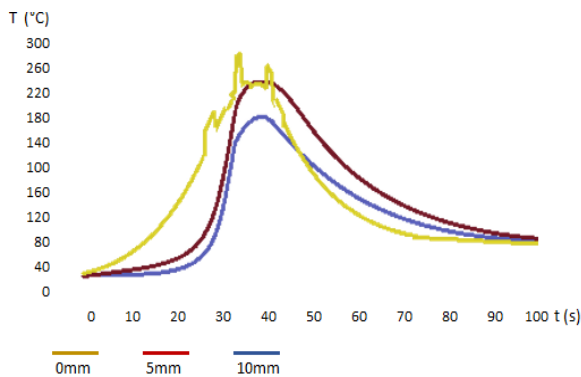

Fig. 16. Temperature at Different Distances from the Weld Bead.

IV. CONCLUSION

In the hot wire cutting machine, the electronic circuit composed of Triac and with the help of the PWM signals generated by the PLC maintains coherence with the linearity of only a maximum error of 1.4%, which allows smooth variations in the voltage, continuously and safely.

In the induction heating machine, it is possible to bring the steel to the temperature necessary for the quenching heat treatment. It is also possible to locate the thermocouple inside the sample, eliminating interference in the signal with a delay of no more than 40 seconds, which could be reduced by increasing the power of the inductor.

In welding, it is important to regulate the advancement speeds of the cord, as well as the measurement of the thermal cycles experienced in the welded area, which was fully accomplished thanks to the implemented automation. To correctly locate a thermocouple on the welded plate, it must be drilled so that when inserting the thermocouple it is spaced between 5 and 10 mm from the center of the weld bead. An online application should be developed to allow remote management outside the laboratory in future work.

ACKNOWLEDGMENT

We thank the company Ingeniería Brasileiro Colombiana SAS for facilitating the laboratory testing infrastructure as well as the thermal processing machines which allowed carrying out this project. We also express our appreciation towards the Francisco de Paula Santander University and the University of Pamplona for their professional and technical support.

REFERENCES

- [1] W. Ma, S. Shi, y X. Zhang, «Three-wire method to characterize the thermoelectric properties of one-dimensional materials», *J. Vac. Sci. Technol. B Nanotechnol. Microelectron. Mater. Process. Meas. Phenom.*, vol. 36, p. 022903, mar. 2018, doi: 10.1116/1.5022118.
- [2] D. G. Ahn, S. H. Lee, y D. Y. Yang, «Investigation into development of progressive-type variable lamination manufacturing using expandable polystyrene foam and its apparatus», *Proc. Inst. Mech. Eng. Part B J. Eng. Manuf.*, vol. 216, n.o 9, pp. 1239-1252, sep. 2002, doi: 10.1243/095440502760291790.
- [3] H. L. Brooks y D. R. Aitchison, «Force feedback temperature control for hot-tool plastic foam cutting», *Proc. Inst. Mech. Eng. Part B J. Eng. Manuf.*, vol. 224, n.o 5, pp. 709-719, may 2010, doi: 10.1243/09544054JEM1717.
- [4] A. L. Voigt, T. V. da Cunha, y C. E. Niño, «Conception, implementation and evaluation of induction wire heating system applied to hot wire GTAW (IHW-GTAW)», *J. Mater. Process. Technol.*, vol. 281, p. 116615, jul. 2020, doi: 10.1016/j.jmatprotec.2020.116615.
- [5] Q. Chen, F. Fei, S. Yu, C. Liu, J. Tang, y X. Yang, «Numerical Simulation of Temperature Field and Residual Stresses in Stainless Steel T-Joint», *Trans. Indian Inst. Met.*, vol. 73, n.o 3, pp. 751-761, mar. 2020, doi: 10.1007/s12666-020-01890-3.
- [6] M. Perić, I. Garašić, Z. Tonković, T. Vuherer, S. Nižetić, y H. Dedić-Jandrek, «Numerical prediction and experimental validation of temperature and residual stress distributions in buried-arc welded thick plates», *Int. J. Energy Res.*, vol. 43, n.o 8, pp. 3590-3600, 2019, doi: 10.1002/er.4506.
- [7] M. F. Ferreira, Â. V. dos Reis, y A. L. T. Machado, «Utilização de revestimento soldado para o aumento da vida útil de sulcadores em semeadoras adubadoras», *Rev. Bras. Eng. E Sustentabilidade*, vol. 2, n.o 2, Art. n.o 2, dic. 2016, doi: 10.15210/rbes.v2i2.8429.
- [8] F. Mühl, J. Jarms, D. Kaiser, S. Dietrich, y V. Schulze, «Tailored bainitic-martensitic microstructures by means of inductive surface

- hardening for AISI4140», *Mater. Des.*, vol. 195, p. 108964, oct. 2020, doi: 10.1016/j.matdes.2020.108964.
- [9] A. Üstündağ y Ç. Gençer, «Designing the Clamp System with the Emergency Braking System in the trains by using PLC and SCADA», en 2021 IEEE 11th Annual Computing and Communication Workshop and Conference (CCWC), ene. 2021, pp. 1436-1441. doi: 10.1109/CCWC51732.2021.9376071.
- [10] M. U. Mahfuz, «Design and Development of a SCADA Course for Engineering Undergraduates», en 2020 IEEE Integrated STEM Education Conference (ISEC), ago. 2020, pp. 1-8. doi: 10.1109/ISEC49744.2020.9280700.
- [11] B. Letowski, C. Lavayssière, B. Larroque, M. Schröder, y F. Luthon, «A Fully Open Source Remote Laboratory for Practical Learning», *Electronics*, vol. 9, n.o 11, Art. n.o 11, nov. 2020, doi: 10.3390/electronics9111832.
- [12] F. J. Maseda, I. López, I. Martija, P. Alkorta, A. J. Garrido, y I. Garrido, «Sensors Data Analysis in Supervisory Control and Data Acquisition (SCADA) Systems to Foresee Failures with an Undetermined Origin», *Sensors*, vol. 21, n.o 8, Art. n.o 8, ene. 2021, doi: 10.3390/s21082762.
- [13] Y. Chen y F. Zhou, «Research and Design of Data Acquisition and Monitoring System for Intelligent Production Line of Prefabricated Building Components», *J. Phys. Conf. Ser.*, vol. 2029, n.o 1, p. 012098, sep. 2021, doi: 10.1088/1742-6596/2029/1/012098.
- [14] D. Muruganandhan, R. Muthunagai, S. Rajkumar, y J. Mohamed Vasif, «Remote Monitoring of Distribution Transformer with Power Theft Detection using PLC amp; SCADA», en 2020 International Conference on System, Computation, Automation and Networking (ICSCAN), jul. 2020, pp. 1-4. doi: 10.1109/ICSCAN49426.2020.9262306.
- [15] K. E. Plewe, A. D. Smith, y M. Liu, «A Supervisory Model Predictive Control Framework for Dual Temperature Setpoint Optimization», en 2020 American Control Conference (ACC), jul. 2020, pp. 1900-1906. doi: 10.23919/ACC45564.2020.9147308.
- [16] E. S. Martynova, V. Y. Bazhin, y V. G. Kharazov, «Increasing the level of control and management of arc steel-smelting furnaces», *IOP Conf. Ser. Mater. Sci. Eng.*, vol. 537, n.o 3, Art. n.o 3, may 2019, doi: 10.1088/1757-899X/537/3/032039.
- [17] D. A. Patiño Epalza, «Diseño de un sistema automatizado para procesos térmicos en la empresa ingeniería brasilero colombiana s.a.s», <http://alejandria.ufps.edu.co/descargas/tesis/1161150.pdf>, 2020, Accedido: 21 de abril de 2022. [En línea]. Disponible en: <http://repositorio.ufps.edu.co/handle/ufps/4506>.
- [18] K. Skalomenos, M. Kurata, H. Shimada, y M. Nishiyama, «Use of induction heating in steel structures: material properties and novel brace design», *J. Constr. Steel Res.*, vol. 148, pp. 112-123, sep. 2018, doi: 10.1016/j.jcsr.2018.05.016.
- [19] H. Sabeeh, I. Abdulbaqi, y S. Mahdi, «Effect of flux concentrator on the surface hardening process of a steel gear», ene. 2018, pp. 80-85. doi: 10.1109/ISCES.2018.8340532.
- [20] H. Kamil, F. Hamdan, F. Abbas, y I. M. Abdulbaqi, «Design and Simulation of a Portable Copper Tubes Induction Brazing Tool for PV System Application», *J. Phys. Conf. Ser.*, vol. 1804, n.o 1, Art. n.o 1, feb. 2021, doi: 10.1088/1742-6596/1804/1/012094.
- [21] N. BarlaDas, P. Ghosh, V. Kumar, N. Paraye, R. Anant, y D. Sourav, «Simulated stress induced sensitization of HAZ in multipass weld of 304LN austenitic stainless steel», 2021, doi: 10.1016/j.jmapro.2020.12.061.
- [22] N. Ma, «Theoretical Prediction of Thermal Cycles and Hardness of HAZ due to Twin Wire Submerged Arc Welding Article in QUARTERLY JOURNAL OF THE JAPAN WELDING SOCIETY • January 2013 DOI: 10.2207/qjws.31.109s READS». 2016.